

Steel Melting Plant

AUTOMATIC SLAG DOOR ENHANCE SAFETY & PERFORMANCE OF SLAG AT LOWER OPERATION COST

Every EAF melting cycle involves the formation of new slag and then its safe removal. Sarralle, in cooperation with leading steelmakers, has engineered a combined automatic slag door and slag channel cleaning device

During EAF operations, un-molten scrap tends to accumulate in the tunnel that extends through the furnace wall from the furnace interior to the slag door opening, limiting the access for the sampling and injection equipment. Furthermore, in that area also the generated slag tends to cold in large quantities. As result, operators must regularly clean out this area by means of specific devices (such as Oxygen lances, mechanical pushers, etc.), a technique that is highly dangerous for the operating personnel. In order to avoid the above mentioned problems on the Slag door area, SARRALLE has developed his own Remote Controlled Slag Door.

FEATURES

- Opening width according to the Upper shell design
- Lifting/lowering actuation by 2 x Hydraulic cylinders (internally water-cooled) with position transducers
- Cooper pusher actuation by 1 x Hydraulic cylinders
- Hydraulic working pressure 160 bar

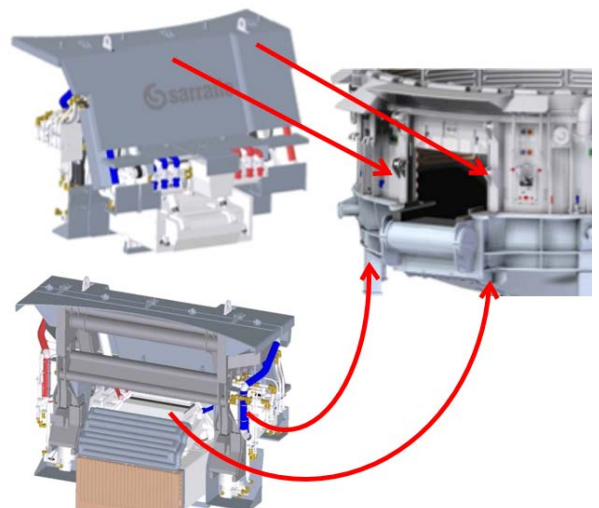

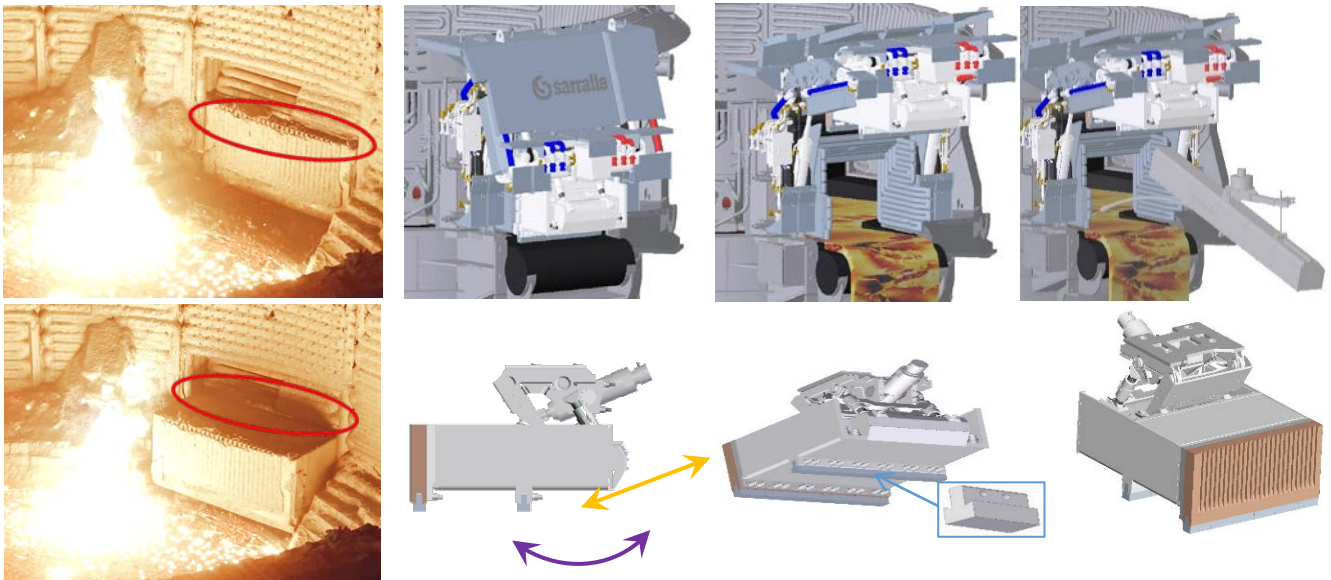

Slag Pushing Operation, door closed, door open for des-lagging and sampling

DESIGN ADVENTAGES

- The lifting/lowering mechanism, lever type, reduces the risk of breakage present in the mechanisms with guides-rails, reduces the occupation of the equipment which results in a lower vertical occupation of space and therefore easy installation also in EAFs with upper shells of small height
- Slag discharging tunnel provided of lateral walls with a height limiting the risk of slag overflow
- The coated flexible hoses' connections are designed with short radius, in order to avoid as much as possible their exposition to heat radiations.
- The Remote Controlled Slag Door is fully hydraulically controlled from the EAF main control pulpit by means of joy-stick with simple and intuitive operations

MAIN BENEFITS

- Increases safety, reducing the presence of workers in the working platform
- Improves the sealing of the furnace
- Improves the cleaning at both sides of the door
- Facilitates the sampling operations
- Minimizes the scrap loss and increases the better use of the steel
- Helps to reduce the sound emissions
- Helps in the formation of foamy slag
- Electrodes consumption reduction
- Carbon consumption reduction
- Refractory consumption reduction (due to reduced electric arc radiation)
- POWER OFF reduction and productivity increase
- Energy consumption reduction



**Bº Landeta, C/ Oredaund Nº 7 Apdo. 1
20730 Azpeitia (Guipuzcoa) SPAIN**

sarralle.com

The information (including, e.g., figures and numbers) provided in this document contains merely general descriptions or characteristics of performance based on estimates and assumptions which have not been verified. It is no representation, does not constitute and/or evidence a contract or an offer to enter into a contract to any extent and is not binding upon the parties. Any obligation to provide and/or demonstrate respective characteristics shall only exist if expressly agreed in the terms of the contract. These estimates and assumptions have to be analysed on a case-to-case basis and might change as a result of further product development. Sarralle excludes any liability whatsoever under or in connection with any provided information, estimates and assumptions. The provided information, estimates and assumptions shall be without prejudice to any possible future offer and/or contract. Any use of information provided by Sarralle to the recipient shall be subject to applicable confidentiality obligations and for the own convenience of and of the sole risk of the recipient.